



GX6/9/12range

GXC6
GX6
GXC9
GX9
GX12

Application:

- Suitable for both domestic and commercial applications including kitchens, restaurants, pubs, offices, factories, schools and shops.

Key Features:

- Stylish design and white appearance to complement and blend with modern décor.
- Trickle ventilation facility for background ventilation when not in use.
- Finger guarded front grille.
- Totally enclosed motor fitted with thermal cut out requires no maintenance.
- Comprehensive range of ancillaries and controllers available.
- 3 Year guarantee (UK).

Features exclusive to GX6.

- Silent shutter operation via a thermal actuator.
- Clip off front cover for sleek appearance and easy cleaning.

Features exclusive to GX9 and GX12.

- High performance axial flow fan providing both extract and intake.
- Silent shutter operation via a thermal actuator.
- Front cover secured by screw.

Features exclusive to GXC9.

- High performance axial flow fan providing extract only.

Operation:

GXC6

- Operated by an integral pull cord switch which simultaneously switches on the fan and opens shutter.

GX6

- Operated by a remote switch (not supplied).

GXC9

- Operated by an integral pull cord switch which simultaneously switches on the fan and opens shutter.

GX9, GX12

- Operated by a remote switch (not supplied), or a controller available as an ancillary.
- Integral mode switch for instant selection of intake, extract or controller operation.

Dimensions:

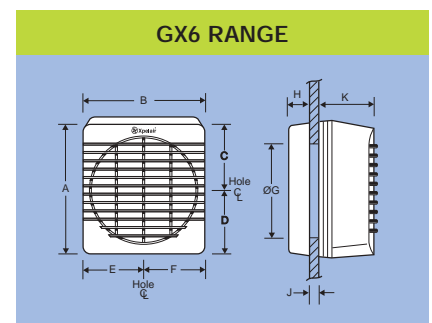

	GX6/GXC6
A	226
D	107
B	210
E	109
C	119
F	101
G	Window 1840 hole Wall 2030 hole to allow for liner
H	32
J	4mm (min), 25mm (max) Window/Wall thickness
K	112
Weight (Kg)	1.9

All dimensions in mm

NOTE: For information on GX Models suitable for domestic applications, see page 34.

Specification:

Product Reference	Catalogue No.		Extract Performance at 240V-50Hz (FID) m ³ /h		Intake Performance at 240V - 50Hz (FID) m ³ /h		Sound Pressure level dB(A) at 3m		Power (Watts)
	Standard	Blister Pack	H/S	L/S	H/S	L/S	H/S	L/S	
GXC6	90850AW	90858BP	266	-	-	-	37	-	30
GX6	90800AW	90808BP	266	-	-	-	37	-	30
GXC9	89995AW	-	549	-	-	-	44	-	32
GX9	89994AW	-	728	618	456	412	50	48	41
GX12	90012AW	-	1614	1214	1002	819	55	50	85

- Minimum performance figures apply only if the fan is used in conjunction with the FR22/30 controller. If used without a controller fans have a single operation at the higher performance.
- Rating for single phase supplies 220 - 240V ~ 50Hz. Class 1 earthed. • International specification available, contact your local Xpelair distributor for details.
- Please refer to the 'Product Comparison Selector' on pages 98 - 103 for full specification detail.

Axial Fan Range

GX6/9/12range

Dimensions:

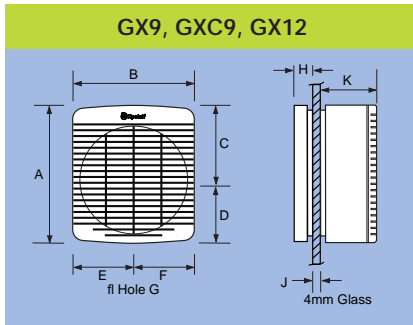

GX9, GXC9, GX12

	GX9/GXC9	GX12	
A	312	408	
B	294	380	
C	165	216	
D	147	192	
E	147	190	
F	147	190	
G	257 \emptyset	324 \emptyset	
H	32	34	
J	Wall/Panel Thickness 4mm		
K	117	161	
	GX9	GXC9	GX12
Weight (Kg)	4.0	3.9	7.9

All dimensions in mm

Installation Dimensions:

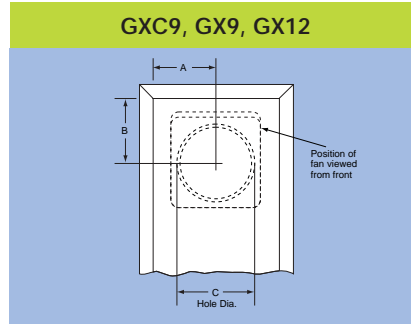

GXC9, GX9, GX12

GX9/GXC9	GX12
A 205 Min	229 Min
B 205 Min	229 Min
C \emptyset Hole in window 257	324
D \emptyset Hole in wall (using WK9/8 & WK9/11)	266
E \emptyset Hole in Wall (using WK12/8 & WK12/11)	330

All dimensions in mm

Wiring Diagrams:

GX6

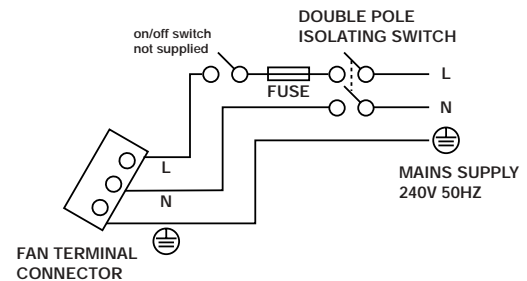

Performance:

GX6, GXC9, GX12

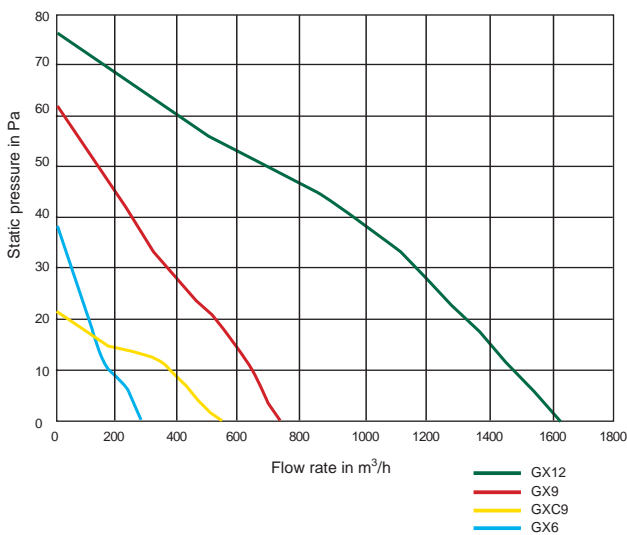

GXC6, GXC6T

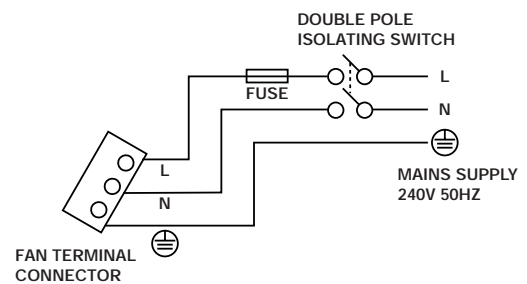

GX9, GX12

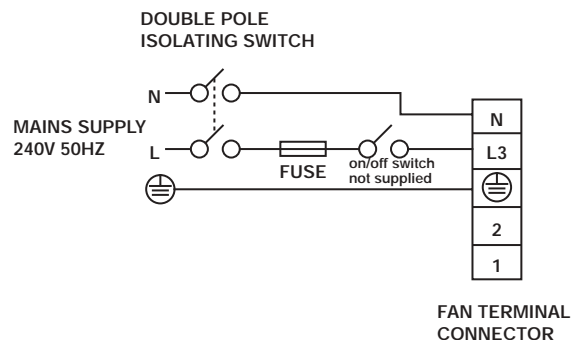

GX6/9/12range

Axial Fan Range

Installation:

GX6 WALL MOUNTING

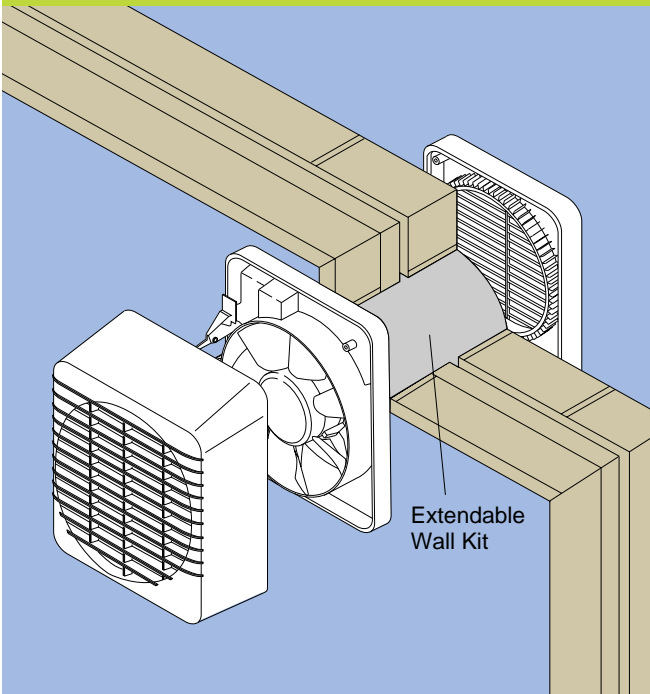

GX9/12 WALL MOUNTED UNIT

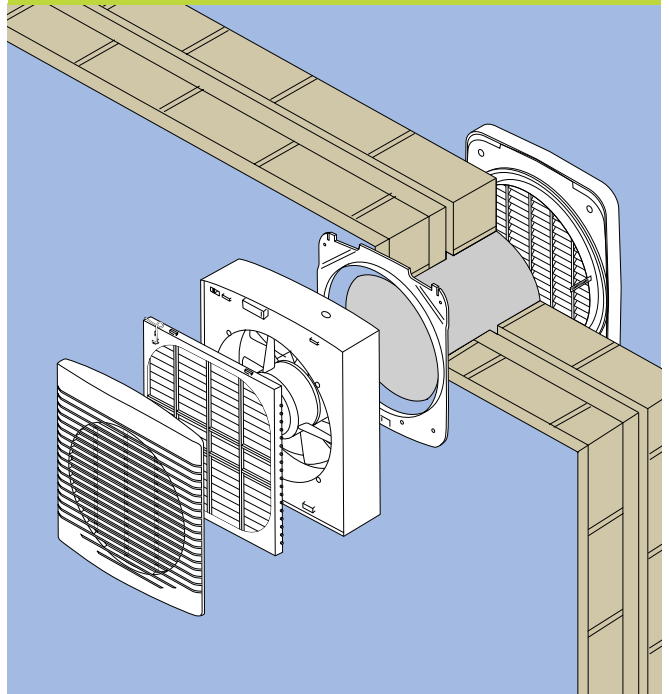

GX6 WINDOW MOUNTING

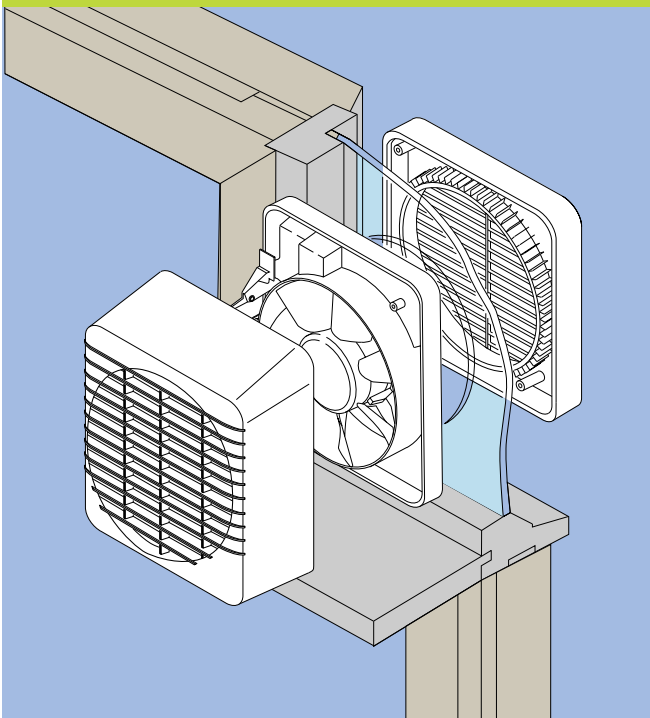

GX9/12 WINDOW MOUNTED UNIT

